

DISCMILL MHA 600 D

Suitable for size reduction and intermediate processing of a wide variety of cereal grains including wheat, maize, rice, barley, and oats.

HIGH PRODUCTIVITY, COMPACT DESIGN

The patented UMS Discmill® type MHA 600 D is designed for a range of size-reduction applications, particularly in the cereal grain milling industry. The main characteristic of this unique grinding technology is very high productivity to the physical size and energy consumption of the machine. Finished product granulation can be controlled over a wide range by the choice of corrugations on the grinding elements, selection of the peripheral speed of the rotating disc, and, whilst in operation, by adjusting the gap between the discs. Depending upon the product and the desired granulation, the Discmill® type MHA 600 D has a capacity of up to 2.000 kg per hour.



Discmill MHA 600 D

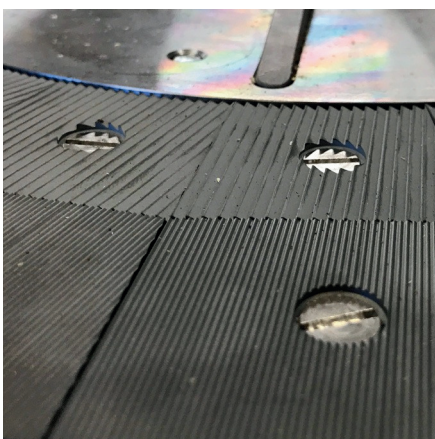

Grinding elements

BENEFITS

- Compact, self-contained design. Minimizes space requirement and installation cost.
- Easily accessible and durable wearing parts. Keep maintenance costs low.
- Rapid disc and element replacement. Minimizes downtime and operating costs.
- Exchangeable grinding elements in various corrugation patterns. Covers a wide range of applications.
- Simple, accurate handwheel adjustment of the grinding gap. This leads to consistent and uniform finished product characteristics.
- Large grinding surface and no integral screen. Gives high capacity and low power consumption.

OPERATION

A regular and constant flow of product enters the inlet (A), located at the top of the Discmill®, and travels through the center of the stationary disc (B) into the milling chamber (C).

The rotating disc (D), mounted on the center shaft (E), is equipped with vanes that accelerate and evenly distribute the product over the grinding surface of the two discs.

The distance between the discs can be accurately adjusted, during operation, utilizing a handwheel, allowing the desired finished product granulation to be achieved. No integral screen is employed and in many applications, subsequent sifting is also unnecessary. The peripheral speed of the rotating disc is selected to suit the application, as is the corrugation pattern on the exchangeable grinding elements. The grinding elements are made from special wolfram carbide alloy which gives exceptional wear resistance.

The ground product is discharged via the outlet (F).

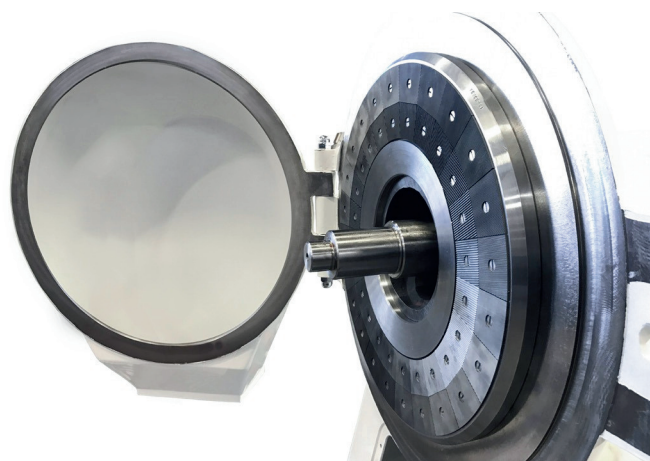

It is recommended that the milling chamber is kept under slight negative pressure, either from a suction pneumatic conveying line connected to the outlet or from an exhaust system.

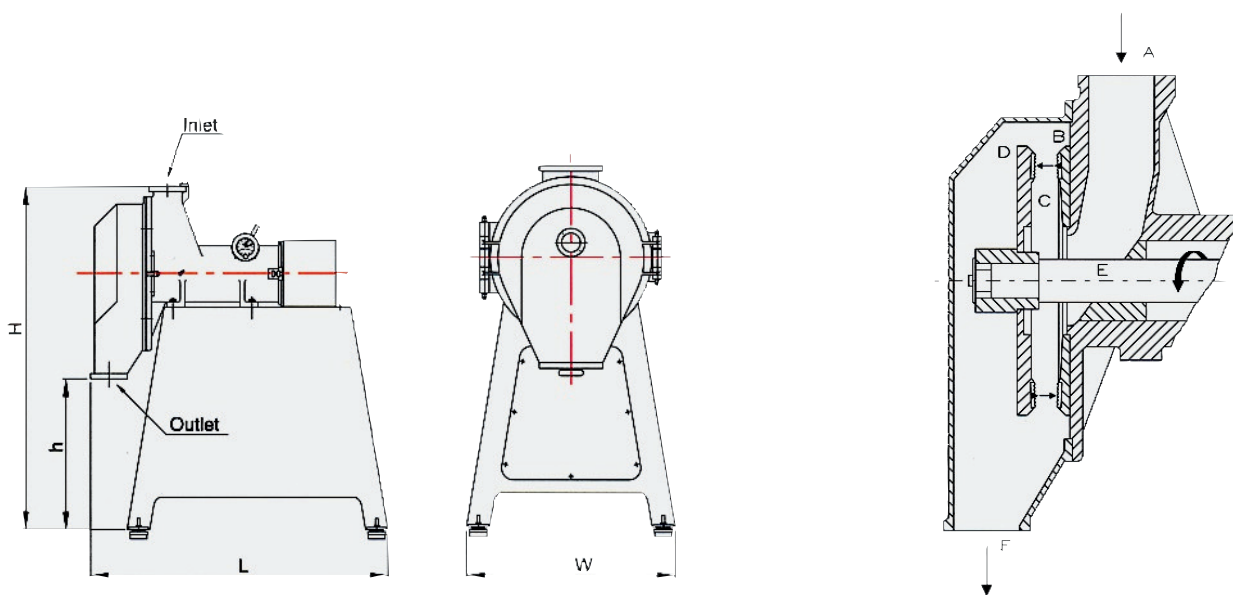

TECHNICAL DATA

Motor Model	Power kW	Cap. kg/h	Ship.vol . m2	Gross weight, kg	Weight net, kg	L, mm	W, mm	H/h, mm
MHA 600 D	37	1500 - 2000	2.5	890	825	1335	890	1530/ 670